

k. stand (Gen. 3) Electric and Extended Electric Installation Instructions and User Manual

Note that these instructions show generic parts. Parts included in individual tables may differ in appearance and functionality but the assembly principle is the same.

Caution: No impact drivers or other high-torque equipment are to be used.

Complete table base

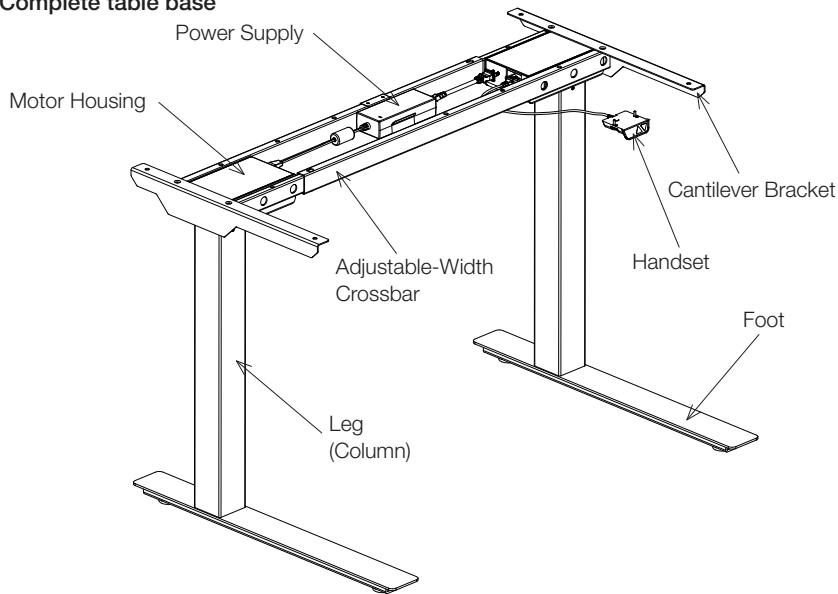

90°

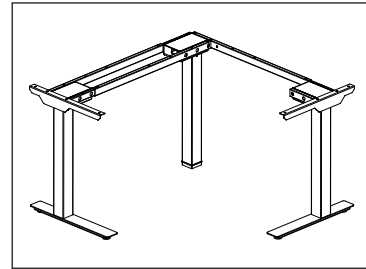

120°

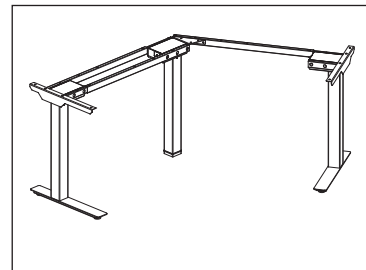

Complete table base with worksurface

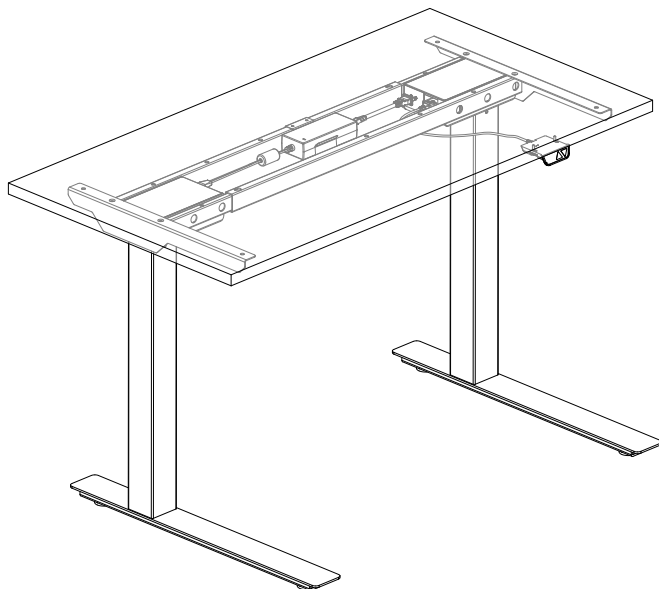

90°

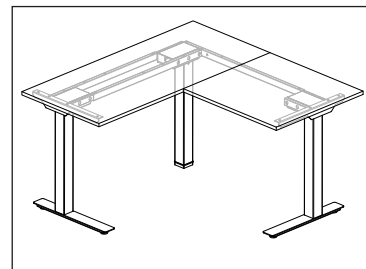

120°

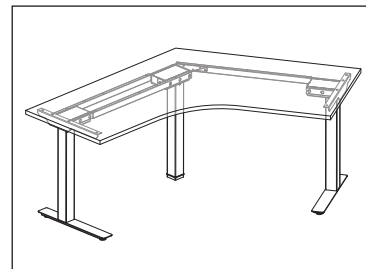

Assembly Procedure

Parts List

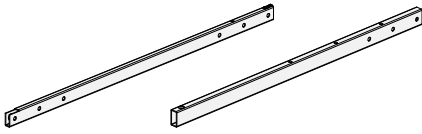

Adjustable Crossbars
(Inner Rail, Outer Rail)



(8) Screw Socket
Flat Head M8 x 16

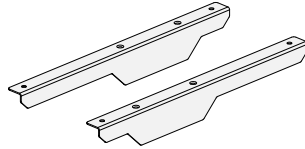

C-Leg Cantilever Brackets



(4) 1/4-20 x 5/8 Undercut
Flat Head, 100 degree

Tools Needed:

Allen key 5mm
Power Driver with #2 and #3 Phillips Bits
(2) 1/2" Open-End Wrenches (For Casters)

Crossbars

1. Orient crossbars so that set screws will be away from the table top.
2. Attach the crossbars on the long side of the motor housings using M8 flat head screws.
3. Tighten screws firmly. (Fig. 1)

Fig. 1

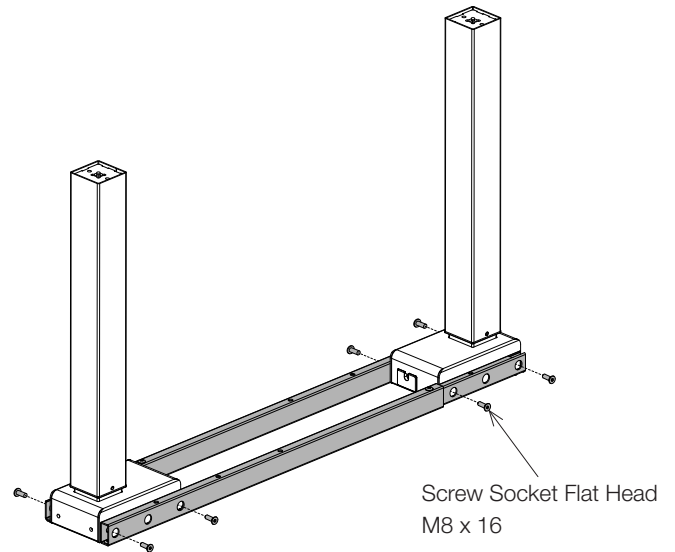

Cantilever Brackets

1. Fasten cantilever brackets in threaded holes on top of crossbars with 1/4-20 flat head screws.

Note: Various base types exist, C-leg version shown. (Fig. 2)

Fig. 2

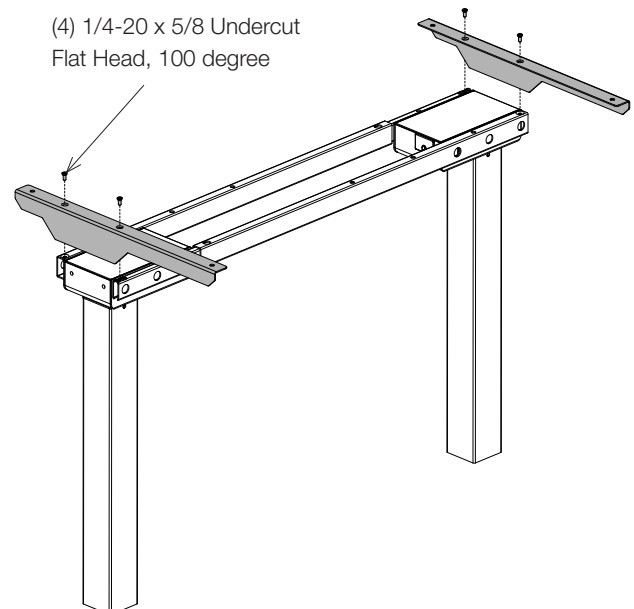

Assembly Procedure, continued

Parts List

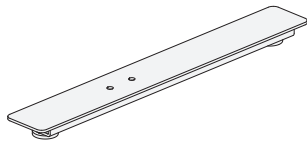

C-Leg Foot

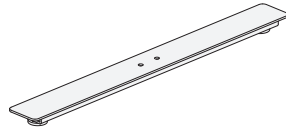

T-Leg Foot

Alternative Foot Types



(4) Screw Socket Button Head
M8 x 16 ZN

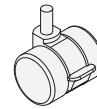

Locking Caster

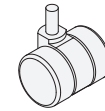

Non-locking
Caster



(2) Hex Nut
5/16-18 x 1/2

Feet

1. Place each foot at end of leg. (For C-legs, orient foot to match cantilever bracket direction). Fasten foot to leg using M8 button head screws. (Fig. 3)

IMPORTANT: Make sure the correct screws are used. Using longer screws may damage parts in the leg.

Maximum Torque from 3 to 5 lb.-ft.

2. When installing casters, use an open-end wrench to hold the 1/2" nut in place inside of the foot.

Fig. 3

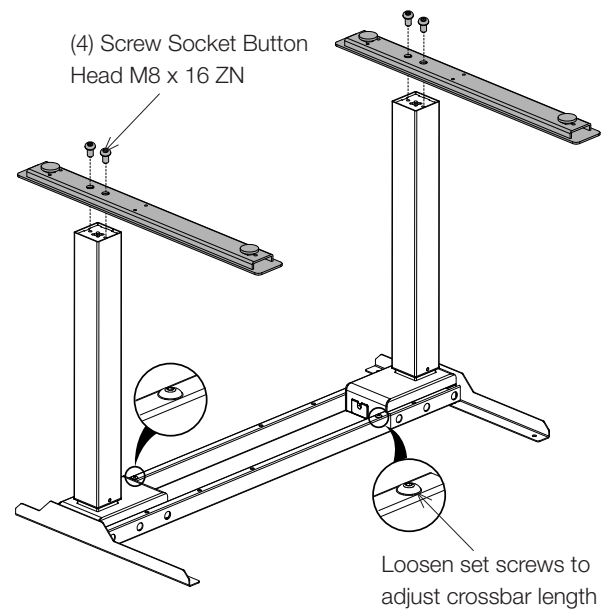

Base Width

1. Loosen the set screws on the crossbars and adjust base to desired width. For typical installations, align holes in crossbar and cantilever brackets with pilot holes in under side of table top. (Fig. 4)

2. Tighten set screw in each crossbar.

Fig. 4

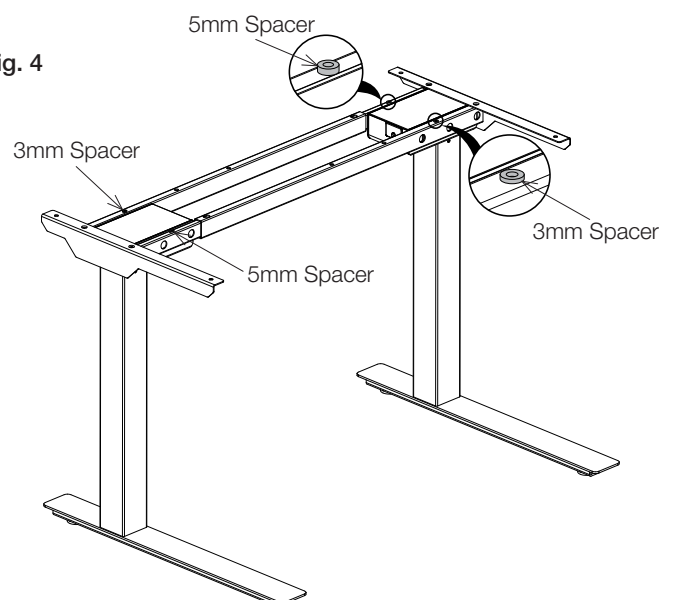

Rigid Spacers

1. Apply rigid spacers to the crossbars as directed on next page.

k. stand Crossbar Screws and Spacers

C-Leg and T-Leg Bases
 C-Leg Bases Shown (from above)

Peel liner paper off and place spacers as shown, encircling the indicated screw holes (except where noted).

Screws should only be driven where spacers have been placed. In some places (noted) spacers will not encircle a screw hole.

Base Width

S: 30" to 36" W
 M: 41" to 45" W
 L: 47" to 51" W

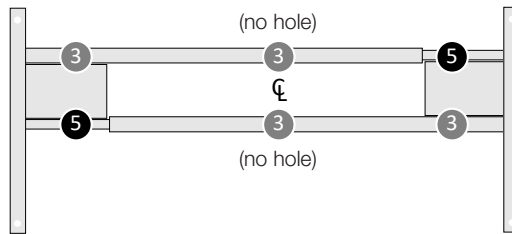

M: 46" to 51" W
 L: 52" to 57" W

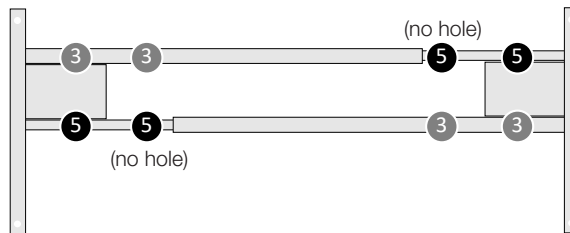

M: 52" to 57" W
 L: 58" to 63" W

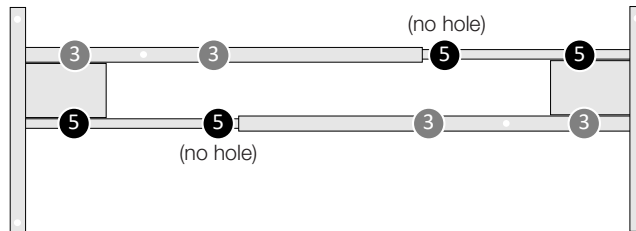



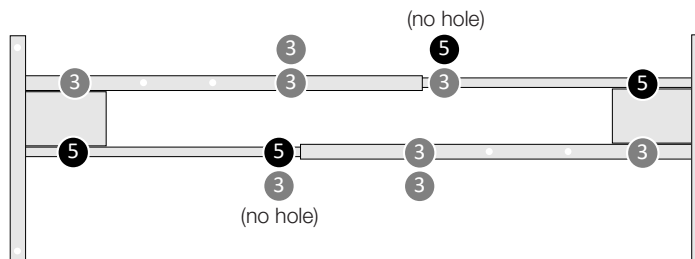

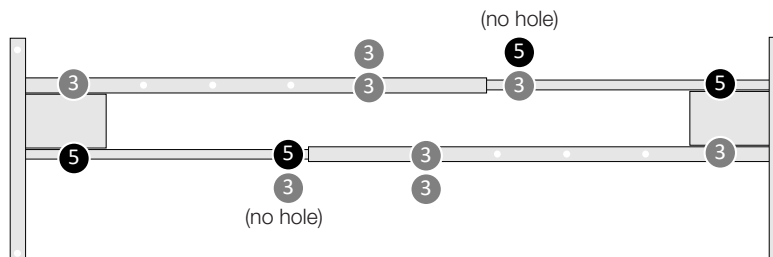

M: 58" to 59.5" W
 L: 64" to 69" W



L: 70" to 71.7" W



	3	Thin Spacer (3mm Thick)
	5	Thick Spacer (5mm Thick)
	3	3mm + 3mm =
	3	(6mm Thick)
	5	5mm + 3mm =
	3	(8mm Thick)
Align spacers when stacking		

Assembly Procedure, continued

Parts List

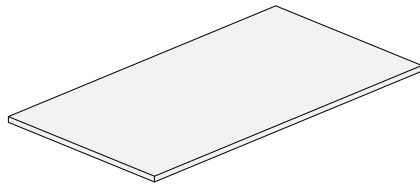

Worksurface



Bracket Worksurface Screw
(4) #10 x 1" Wood Screw



Crossbar Worksurface Screw
#10 x 2 1/2" Wood Screw
(4 min/10 max)

Side Bracket to Worksurface

1. Two sizes of wood screw for the worksurface are included in the 2-leg assembly kit, and an additional size in the 3rd leg assembly kit.

#10 x 1" Wood Screw Pan Head

#10 x 2 1/2" Wood Screw Flanged Pan Head

#14 x 2 1/2" Wood Screw (3-leg bases only)

2. The shorter screws through cantilever brackets.

IMPORTANT: These screws require a minimum 1" thick work top.

Fig. 5

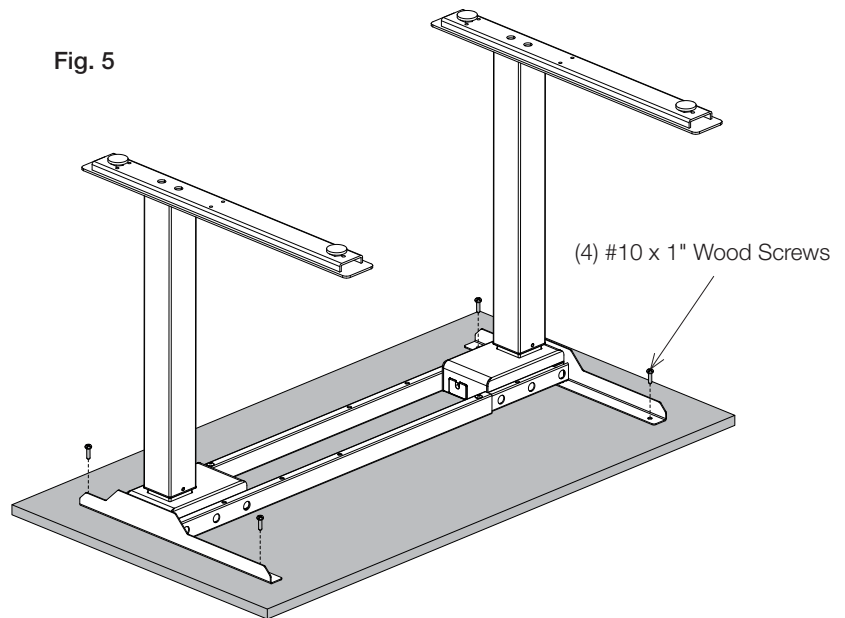

Crossbar to Worksurface

NOTE: A spacer (or stack of spacers) is to be used at every crossbar to worksurface screw.

1. Install screw thru crossbar and spacer into worksurface. (Fig. 6)

Fig. 6

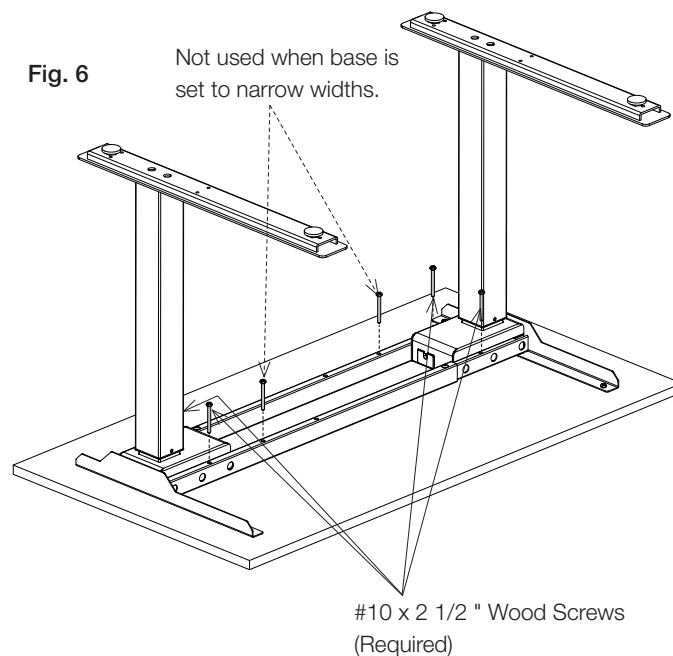

k. stand Crossbar Screws and Spacers

Left Side of 90° and 120° Corner Bases Bases Shown (from above)

Do not use the Rubber Bumpers (if included in the hardware kit).

Peel liner paper off and place spacers as shown, encircling the indicated screw holes (except where noted).

Screws should only be driven where spacers have been placed In some places (noted) spacers will not encircle a screw hole.

Base Width

S: 30" to 36" W
M: 41" to 45" W
L: 47" to 51" W

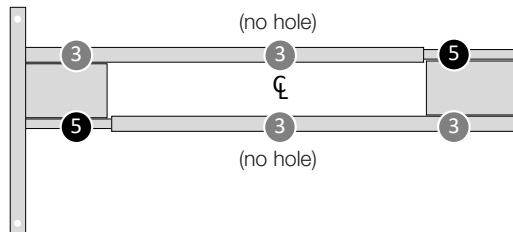

M: 46" to 51" W
L: 52" to 57" W

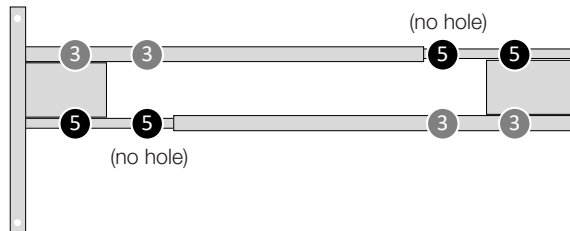

M: 52" to 57" W
L: 58" to 63" W

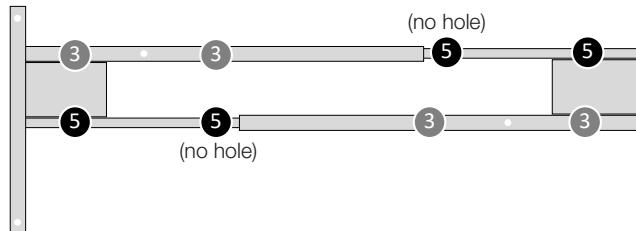



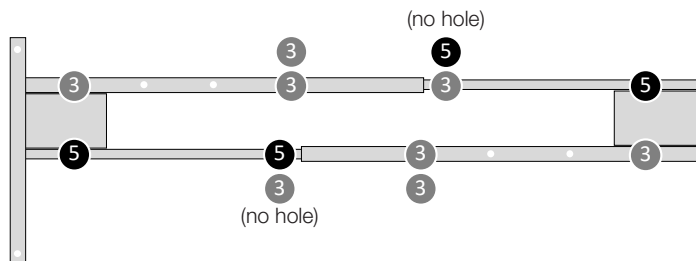

M: 58" to 59.5" W
L: 64" to 69" W

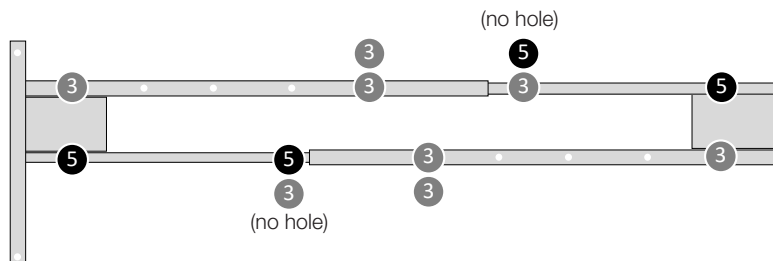

L: 70" to 71.7" W



	3 Thin Spacer (3mm Thick)
	5 Thick Spacer (5mm Thick)
	3 3mm + 3mm = 3 (6mm Thick)
	5 5mm + 3mm = 3 (8mm Thick)
Align spacers when stacking	

k. stand Crossbar Screws and Spacers

Right Side of 90° and 120° Corner Bases
Returns Shown (from above)

Do not use the Rubber Bumpers (if included in the hardware kit).

Peel liner paper off and place spacers as shown, encircling the indicated screw holes (except where noted).

Screws should only be driven where spacers have been placed In some places (noted) spacers will not encircle a screw hole.

Return Width

S: 30" to 36" W
M: 41" to 45" W
L: 47" to 51" W

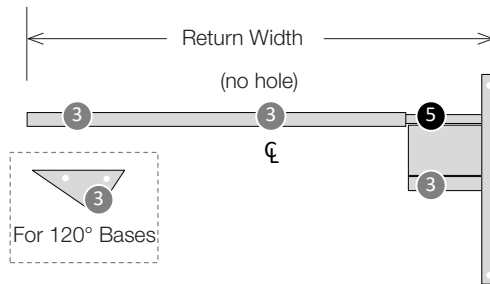

M: 46" to 51" W
L: 52" to 57" W

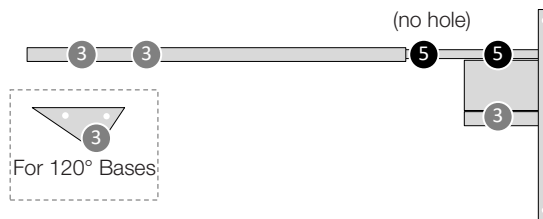

M: 52" to 57" W
L: 58" to 63" W

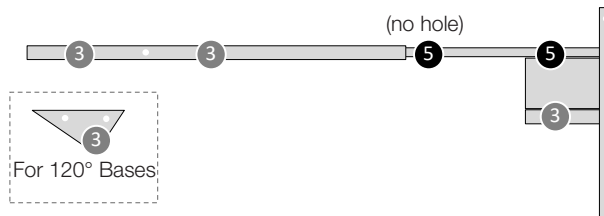



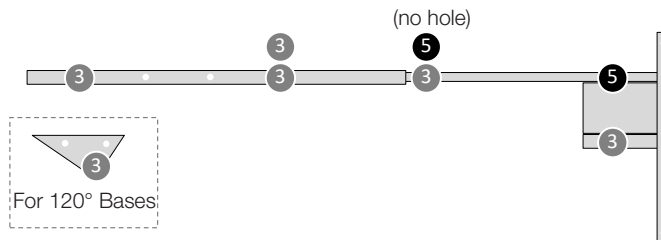

M: 58" to 59.5" W
L: 64" to 69" W

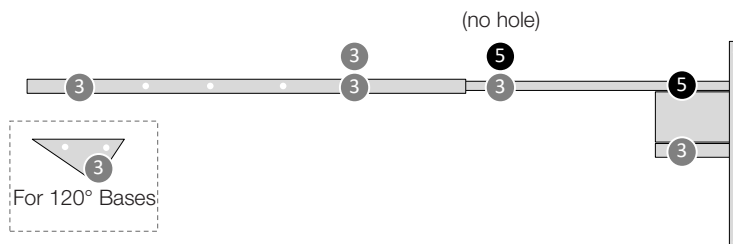

L: 70" to 71.7" W



	3 Thin Spacer (3mm Thick)
	5 Thick Spacer (5mm Thick)
	3 3mm + 3mm = 3 (6mm Thick)
	5 5mm + 3mm = 3 (8mm Thick)
Align spacers when stacking	

Assembly Procedure, continued

Parts List

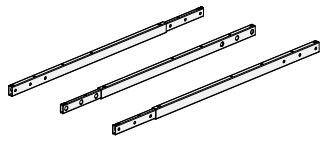

Adjustable Crossbars
(Min. 40.4" to Max. 58.75")

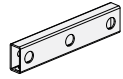

40 x 20 Fixed Crossbar

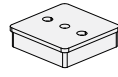

3rd Leg Foot



(2) Screw Socket
Button Head
M8 x 16



(2) Screw Socket
Flat M8 x 16 ZN



(3) #14 x 2 1/2
Wood Screw

3-Column 90° Table

1. Three (3) adjustable crossbars are used along with one (1) short fixed crossbar. Short fixed crossbar is always installed on front face of RH motor housing.
2. The 3rd leg foot is used on the middle column.
3. Install 3rd crossbar with two (2) socket flat M8 x 16 ZN in to the back of the middle column motor housing. (Fig. 7)

Fig. 7

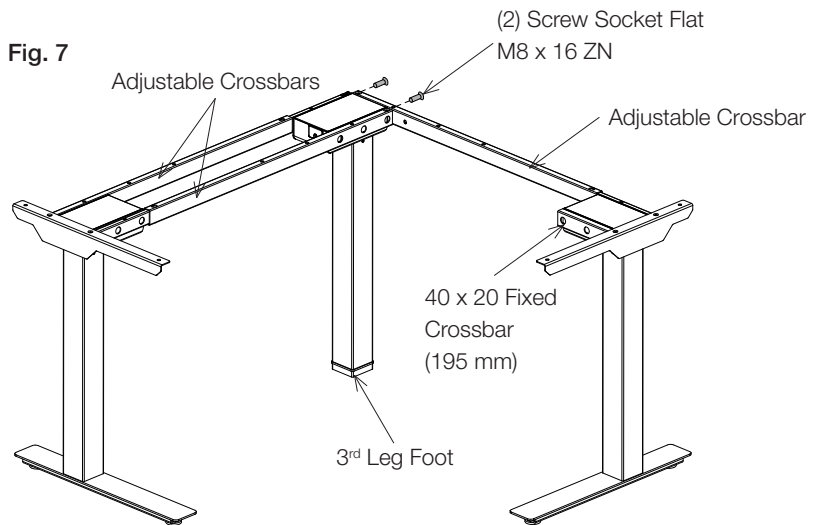

Two (2) adjustable crossbars on LH side,
one (1) adjustable crossbar on back of RH side.

90° Worksurface Screws

1. Be sure to install #14 x 2 1/2 wood screws in all three (3) crossbar locations near center column. (Fig. 8)

Fig. 8

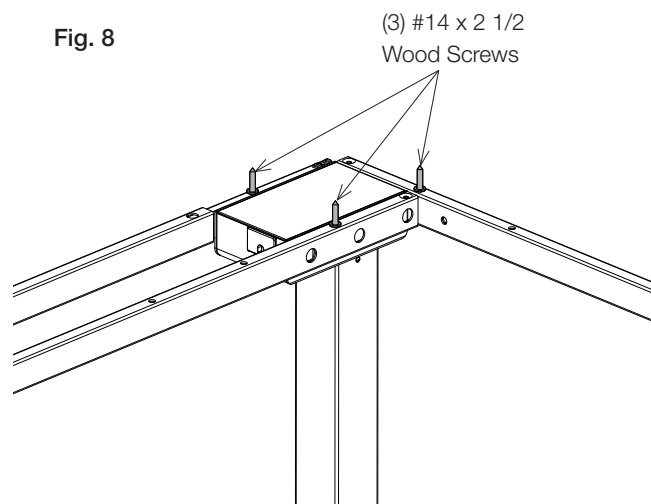

Assembly Procedure, continued

Parts List

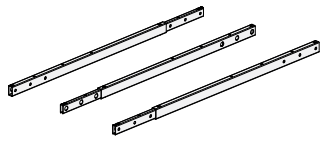

Adjustable Crossbars
(Min. 40.4" to Max. 58.75")

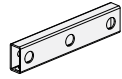

40 x 20 Fixed Crossbar

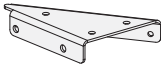

120° Bracket

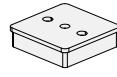

3rd Leg Foot



(2) Screw Socket
Button Head
M8 x 16



(8) Screw Socket
Flat M8 x 16 ZN



(3) #14 x 2 1/2
Wood Screw

120° Assembly Close-up

1. Three (3) adjustable crossbars are used along with one (1) short fixed crossbar and a 120° bracket that attaches to the middle column.
2. When installing 120° bracket, be sure to install bracket to motor housing before attaching crossbar to bracket.

Fig. 9

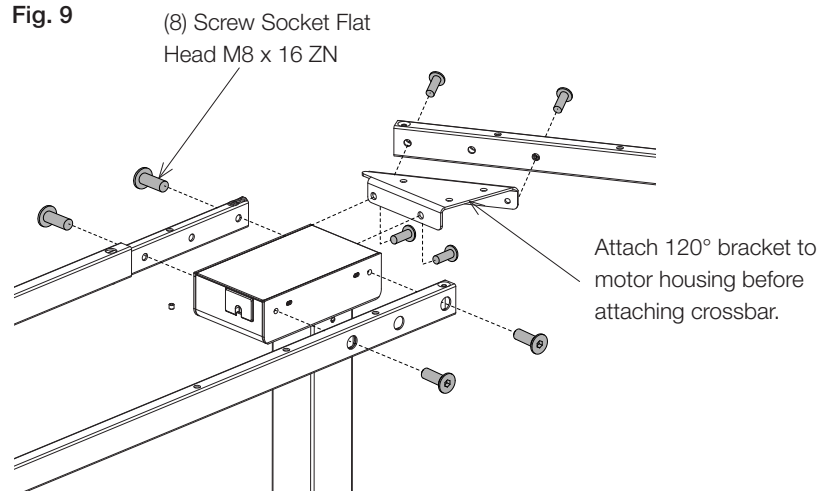

Two (2) adjustable crossbars on LH side,
one (1) adjustable crossbar on back of RH side.

3-Column 120°

1. The 3rd leg foot is used on the middle column.

Fig. 10

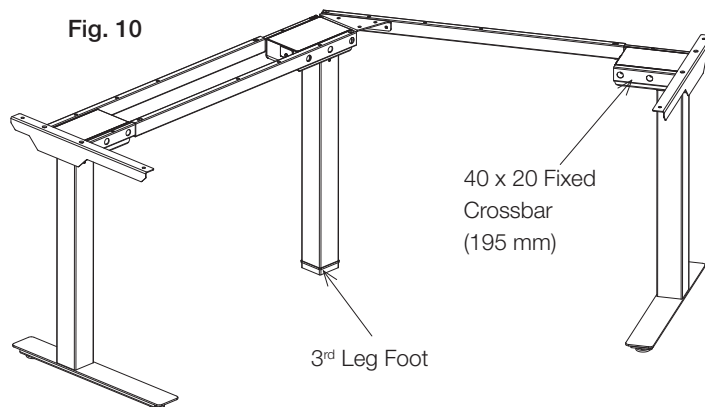

Assembly Procedure, continued

120° Assembly Close-up

1. Be sure to install #14 x 2 1/2 wood screws in all three (3) crossbar locations near center column, and #10 x 1" wood screw in one of the 120° bracket screw hole locations. (Fig. 11)

Fig. 11

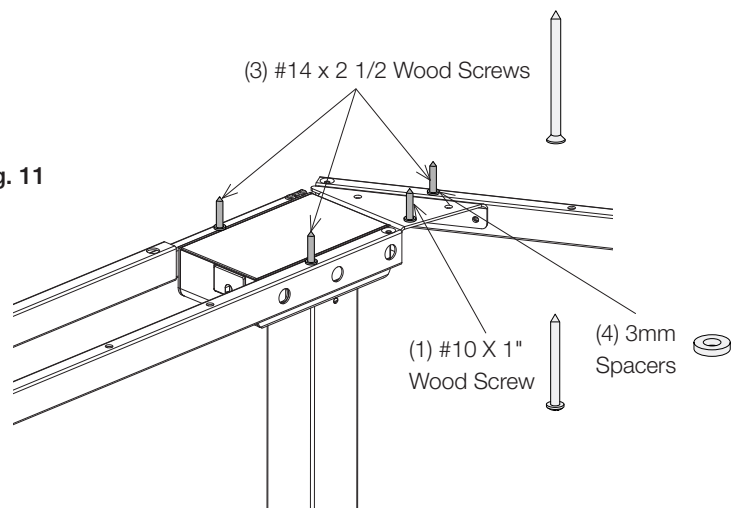

90° and 120° Worksurface Screws

1. Install screws thru crossbar and spacer to worksurface. (Fig. 12)

Fig. 12

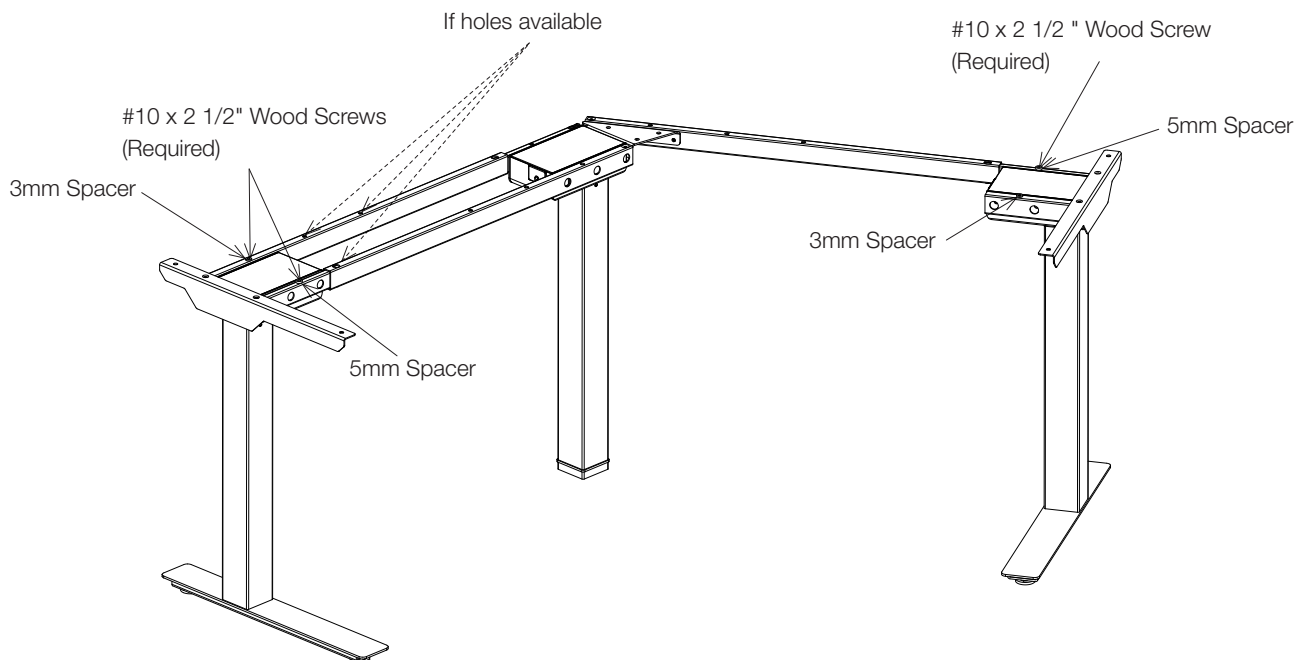

Assembly Procedure, continued

Parts List

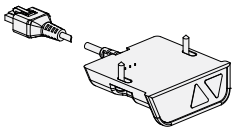

Standard Handset

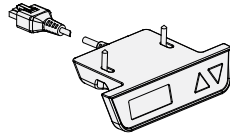

Digital Handset

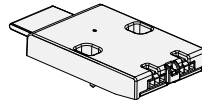

Toggle Handset

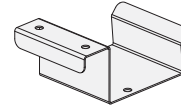

Holder for Power Supply
(Hooks over crossbar or screws into worksurface)

Electrical 2-Column

1. The handset is mounted at the front edge of the worksurface, screwed to the underside with screws supplied with the unit. Connect the cables and power supply according to figures 13-15.

Fig. 13

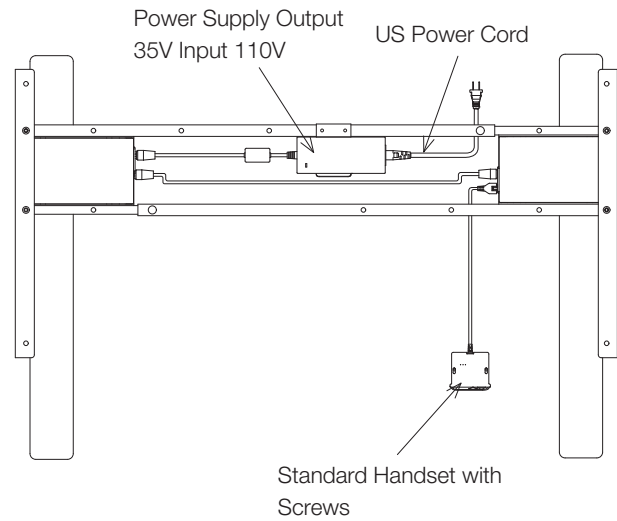

Electrical 3-Column 90°

Fig. 14

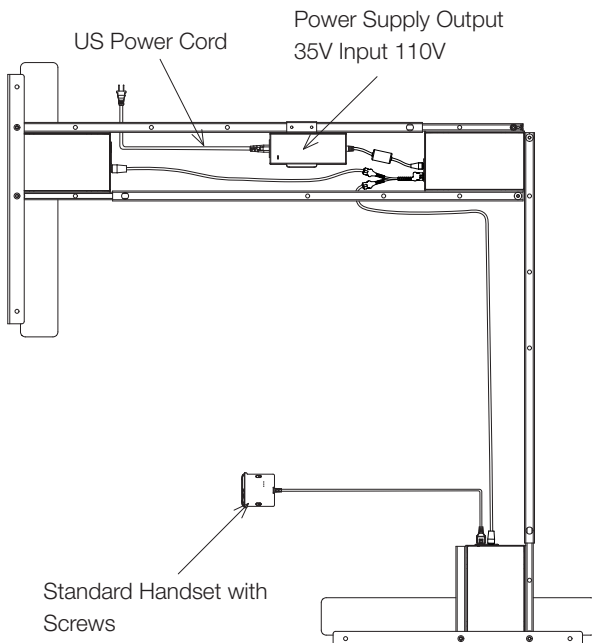

Electrical 3-Column 120°

Fig. 15

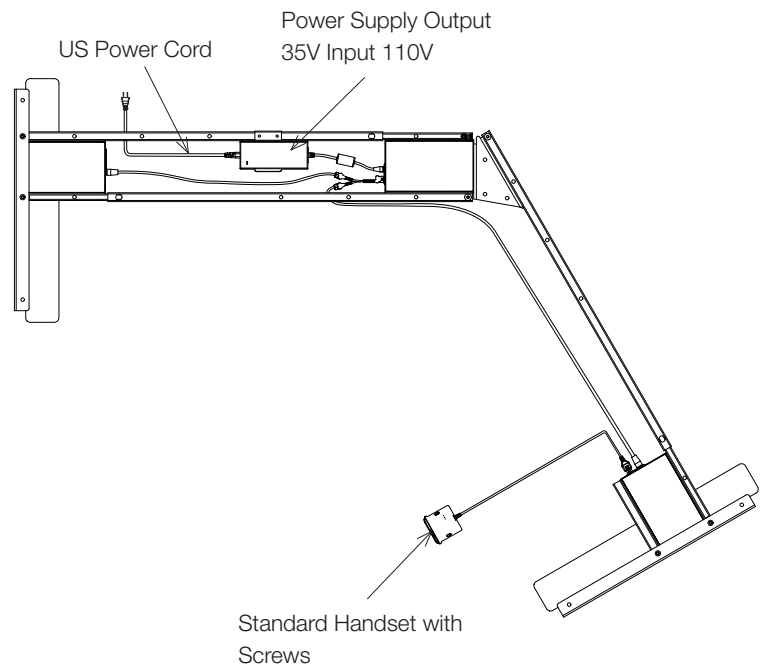

Knoll

k.stand (Gen. 2) Height-Adjustable Table

Standard Electric and Extended Electric – Stroke 650/470

User Manual



Knoll, Inc.
Customer Service
1235 Water Street
East Greenville, PA 18041

Contents

1	Important Information. SAFETY FIRST!	3
1.1	Important safety instructions, please save these instruction.	4
1.2	User Information	6
1.3	Before you start:	6
1.4	Electrical rating	6
2	Assembly & Adjustment	7
2.1	Assembly Instruction	7
2.2	Setup procedure	7
2.3	Optional mounting guidelines	8
2.4	System configuration (example)	8
2.5	Adjustments	9
3	Operation Instructions	10
3.1	Basic functions	10
3.1.1	Upward desktop movement	11
3.1.2	Downward desktop movement	11
3.1.3	Simple memory, end positions	11
3.2	Advanced functions, Manuel reset	12
4	Maintenance & Repairs	13
4.1	Cleaning, Inspection and Storage	13
4.2	User Maintenance	13
4.3	Repairs	13
4.4	Servicing of double-insulated products	14
5	Appendix	15
5.1	Accessories, Series EE, ECS+	15
5.2	Dimensions column system: Series EE, ECS+ with 665 stroke BIFMA	16
5.3	Dimensions column system: Series EE, ECS+ with 420 stroke	17

1. Important Information—Safety First!

Your safety and the safety of others are very important. Please familiarize yourself with all instructions and safety warnings before operating the table. Please keep this manual for future reference.

To help you make informed decisions about safety, we have provided operating procedures and other information on labels and in this user's manual. This information alerts you to potential hazards that could hurt you or others. It is not practical or possible to warn you about all the hazards associated with operating or maintaining a table. Please use your own good judgment.

You will find important safety information in a variety of forms. Safety Messages are preceded by a safety alert symbol  and one of three signal words: **DANGER**, **WARNING**, or **CAUTION**. These safety messages are listed in order of severity, identify the general risks and what actions you are to take to avoid the risks. These signal words mean:

DANGER

Indicates an imminent hazard with a high risk of serious injury or death.

WARNING

Indicates a potential hazard that could result in serious injury.

CAUTION

Indicates a potentially hazardous situation, which could result in minor or moderate injury. It may also be used to alert against unsafe practices.

NOTICE

Indicates an alert to call attention to proper assembly instructions or particular operation procedures to assure correct equipment function and to avoid equipment damage or wear.

The information and specifications included in this manual were in effect at the time of approval for printing. ROL reserves the right to discontinue or change specifications or design at anytime without notice and without incurring any obligation whatsoever.

1.1 Important safety instructions. Please save these instructions.

Please save these instructions.

When using an electrical table, basic precautions should always be followed, including the following:

Read all instructions before using table.

DANGER—To reduce the risk of electric shock:

1. Always unplug this furnishing from the electrical outlet before cleaning or servicing.

WARNING—To reduce the risk of burns, fire, electric shock, or injury to persons:

1. Unplug from outlet before putting on or taking off parts.
2. This table is not intended for use by children or individuals with a physical or other impairment that may affect the ability to safely operate equipment.
3. Use this table only for its intended use as described in these instructions. Do not use attachments not recommended by the manufacturer.
4. Never operate this table if it has a damaged cord or plug, if it is not working properly, if it has been dropped or damaged, or exposed to water. In the event of any such event please return the table to a service center for examination and repair.
5. Keep the cord away from heated surfaces.
6. Never operate the table with the air openings blocked. Keep the air openings free of lint, hair, and the like.

7. Never drop or insert any object into any opening.
8. Do not use outdoors.
9. Do not operate the table in a potentially explosive atmosphere.
10. To disconnect, turn all controls to the off position, then remove plug from outlet.

WARNING—Risk of electric shock, fire and injury.

Review the assembly instructions to confirm that the appropriate critical components and accessories are being used with the furnishings.

1. Connect this table to a proper outlet only. For loading always put heavier items at the bottom and not at the top in order to help prevent the possibility of the furnishing tipping over.

WARNING—Risk of injury to persons.

1. Do not use this table to lift people and do not use the table to lift heavy parts or use this table as a platform for storage.
2. Maximum intended load is 265 pounds uniformly distributed (120 kilograms) including the table top.

DANGER—Risk of electric shock, injury, or death:

1. Improper usage, abuse, or misuse of the power supply, handset, motors and other electrical components may result in an electrical shock injury or possible death.
2. Do not open the power supply unit or handset under any circumstances. The power supply and handset contain no serviceable parts.
3. Do not modify or make any changes to the power supply, handset or other electrical devices.
4. During installation, repair, cleaning, or maintenance work, the power cable must be disconnected from the outlet.
5. The engines/motors control unit is not designed for continuous operation. Changing the desktop position without interruption must not exceed the duty cycle indicated on the power supply. The unit is thermally protected and will temporarily shut down if use exceeds the duty cycle. Allow a 9-minute cooling period for the control unit to reset.
6. The power supply unit may only be operated with voltage as specified on the power supply label.
7. Only use the power cord supplied with the power supply. Check that it is not damaged. Do not operate the power supply unit if the power cord is damaged.
8. Connect the power supply to a proper outlet only. To disconnect turn all controls to the off position, then remove plug from outlet.
9. In the event of a malfunction (e.g. if the control unit keeps adjusting the desk because a movement button has jammed), please unplug the unit immediately.
10. Do not expose the power supply, control unit/ECS+, handset or other electrical device to water or other liquids including moisture, drips, splashes or spills. Only clean electrical device with a dry cloth.
11. Do not operate the power supply, control unit/ECS+, handset or other electrical device in a potentially explosive atmosphere. Do not operate where aerosol spray products are being used or where oxygen is being administered.
12. Do not use the desk with if it has been dropped or damaged. Contact the manufacturer for examination or repair.
13. It is not allowed to connect self-constructed products to the power supply, control unit/ECS+, handset or other electrical device. To prevent damage, use only components recommended by the manufacturing company.

WARNING—Risk of injury, or death:

1. During the raising or lowering of the table there exists a risk of squeezing or pinching between the moving desktop and fixed objects.
2. The necessary safety margins depend on the greatest type of injury risk that can be predicted. Where possible small pinch points exist (i.e. fingers) use at least a one inches (2,5 cm) safety margin and for body or head (especially where children may be present) use a minimum of 16 inches (41 cm) count from the floor or from their top of the table feet if that is relevant.
3. During the lowering or rising of the desktop, the operator must ensure that no person or object risk being harmed by the operation.
4. This tag (at right) should be located on the table during the initial installation.
5. Keep children away from moving parts and underneath the table.
6. The intended use of the table is adjusting a work surface between sitting and a standing position. The table is not designed for other uses.
7. The table must only be operated while in an upright position and must under no circumstances be operated while upside down.
8. The table must not be overloaded. The maximum allowable load is shown on the power supply label.
9. The table must be operated in a dry, enclosed space, such as an office or similar; Do not operate outdoors.
10. The table is equipped with an Anti-Collision (AC) function. In the event of a faulty the desktop may move slightly before the safety feature is engaged. Stay clear of pinch points when the desktop is moving.
11. This table is not intended for use by individuals (including children) with limited physical, sensory or mental abilities or with a lack of experience and/or lack of expertise, unless they are supervised by a person responsible for their safety or have received instructions from that person on how to use the control unit.
12. Children must be supervised at all times to ensure that they do not play with the control unit.
13. The table may not be used to lift people. Do not sit or stand on a table while it is be raised or lowered.
14. The table must not be structurally or technically altered or modified in any way.

1.2 User Information

This column system is rated for commercial use only and is rated for a maximum load of 265 pounds, uniformly distributed (120kg) including the tabletop

The motors may only be used continuously for 1 minute after which the table will automatically shut-off 9 minutes.

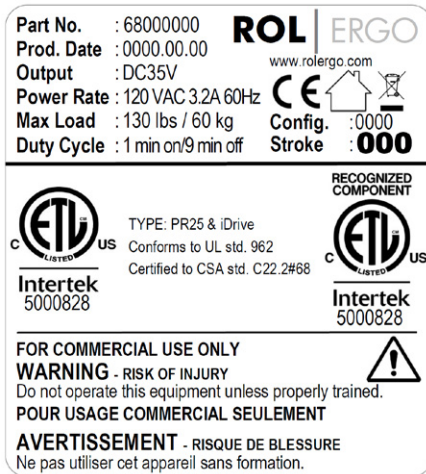

Typical Product Label with Date of Manufacture

1.3 Before you start:

Check for and remove obstacles in path of the table top.

Before first use, the control unit must register the lowest point of elevation. Do the reset as **section 3.2**. Under normal conditions the system communicates internally and knows the position of each column.

If there are differences in column height, please do a manual reset as listed in **section 3.2**.

1.4 Electrical rating

Electrical rating, input: 120VAC, 50-60Hz, 3,2A.
 Output 35V.

2 Assembly & Adjustment

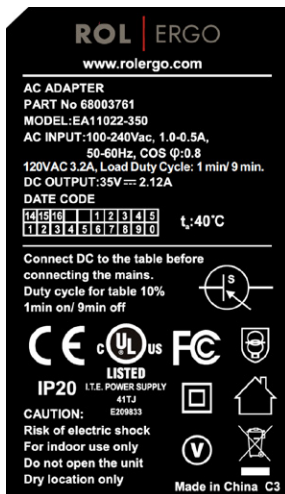

Power supply for 40mm/sec speed

2. Assembly & Adjustment

2.1 Assembly Instruction

The official assembly instruction will be found with the base components.

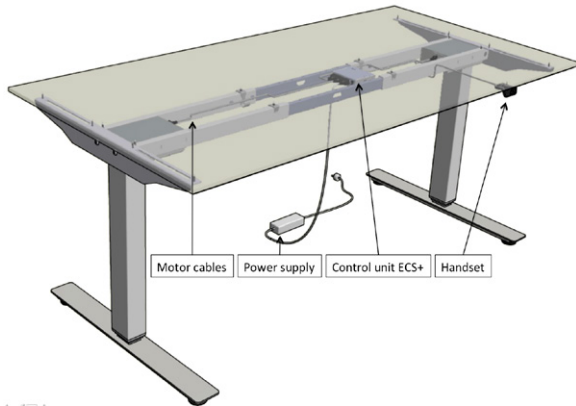

Make sure to ask your desk vendor for an approved combination of desktop and frame.

3. Connect the Power Supply to the control unit / ECS+

4. Connect the power supply to the outlet.

At first use, the control unit must register the lowest position. To do this, press the “down” icon and go to the lowest level.

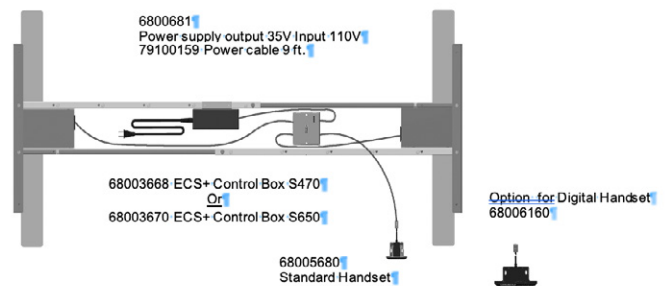

2.2 Setup procedure

CAUTION—Risk of electrical shock:

The power cord must be unplugged while the control unit is being commissioned.



This table is equipped with ROL ECS+ system, to setup the controlling device proceed as follows.

1. Connect the motor cables to the control unit 8-pin motor cables (2). When there are 2 motors, connect to socket 1 and 2.
2. Connect the handset to the relevant socket on the control unit / ECS+

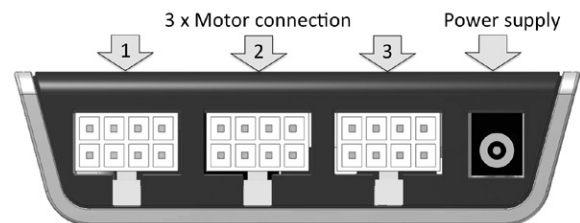

Reset together with installation



- 1-Drive the columns down to lowest level
- 2-Ready for use

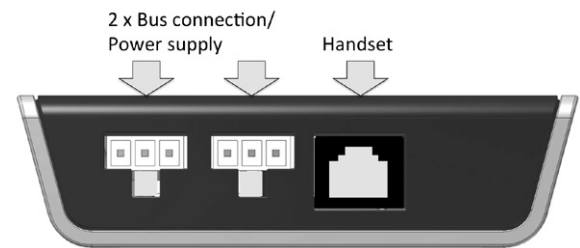

2.3 Optional mounting guidelines

! NOTICE

When disconnecting components such as power supply, control unit / ECS+ or motor cables, the strain relieve hook must be pressed before removing the connector. When inserting the connector, an audible “click” indicates that the strain relieve hook has correctly re-engaged.

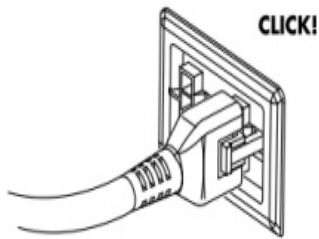

! DANGER—Grounding Instruction

This product does NOT require grounding to earth. This product is double insulated and equipped with a non-polarized 120V plug and 2-conductor cord. The plug must be plugged into an appropriate building outlet that is properly installed in accordance with all local codes and ordinances.

! DANGER—Risk of electrical shock

Improper connection of the equipment can result in a risk of electric shock. Check with a qualified electrician for any concerns. Do not modify the plug provided with the product—if it will not fit the outlet have a proper outlet installed by a qualified electrician.

This product is designed for the voltage indicated on the power supply label. No adapters should be used with this product.

! CAUTION—Risk of electrical shock

Before you plug in the power cord, check the following again:

- The voltage must be as specified on the power supply label.
- When the power cord is plugged in, the electrical control devices are operational.

! NOTICE

In case of a main power breakdown, or if the power cord is unplugged during the movement of the drives, a manual reset may be necessary! Please see **section 3.2** manual reset.

2.4 System configuration (example)

The figure below shows the motor driving assignment for a configuration example. This configuration consists of:

- 1 Power Supply
- 2 Motor cables
- 3 Handset
- 4 Control unit

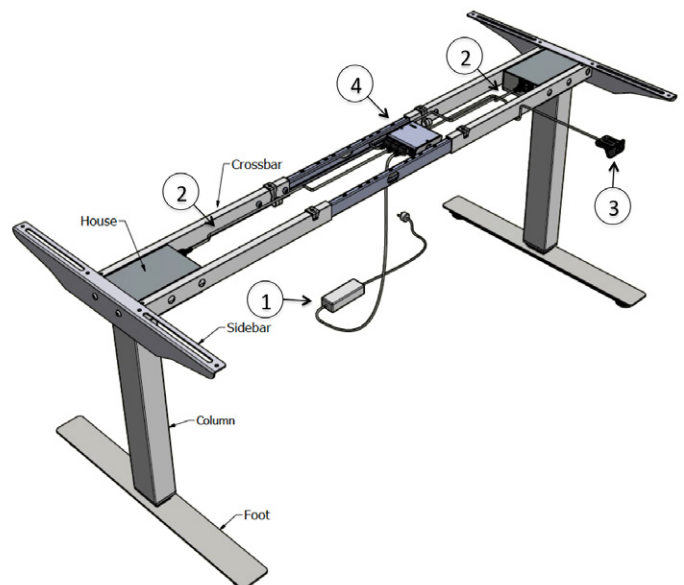

2.5 Adjustments

The table control, handset and motors are sealed units and have no parts that can be serviced or adjusted by the user. In case of failure or unexpected operation or for maintenance contact your vendor and arrange for service by a qualified technician.

3 Operation Instructions

To ensure safe operation of the ECS+ control unit, please observe the following safety instructions:

CAUTION—Risk of injury and electric shock

Keep children away from electric height-adjustable desks, control units and handset.

CAUTION—Risk of pinching

When you change the desktop position (especially without using pinch protection), you must ensure that no people or objects are located in the hazardous area nor may reach into it.

NOTICE

In case of a main power breakdown, or if the power cord is unplugged during the movement of the drives, a manual reset may be necessary! Please see **section 3.2**.

NOTICE

The control unit might be damaged by power surges. Unplug the power cord during a thunderstorm or if you do not intend to use the desk for a longer period.

3.1 Basic functions

NOTICE

You must read the user manual carefully before installing or operating the control unit.

If chosen handset doesn't fit to this user manual, please see separate user manual for actual handset.

Overload protection!

If the total load on the equipment is too high you will only be able to drive for 2 seconds. The system will then stop and you need to take weight off the table. After some weight is removed, adjust the table again.

Overheat protection!

If heavy loaded and driven continuously for a long period of time the motor may overheat. The software registers this and, if overheated, system will shut down and you will have to wait 9 minutes before being using the table again.

Anti-Collision "AC"!

The ECS+ is equipped with intelligent software for pinch protection. If a collision is detected system will stop and back off about 1 inch.

IMPORTANT! Make sure to remove the blocking item causing the pinch before trying to operate the table again. Failure to do so may cause injury to user or equipment.

3.1.1 Upward desktop movement

This function enables you to adjust the desktop upwards. To change its position, proceed as follows: Press the handset “up” button. Keep pressing the button until the required desktop height is reached.



! NOTICE

The desktop will continue moving upwards until you release the button or the maximum height is reached

3.1.2 Downward desktop movement

This function enables you to adjust the desktop downwards. To change its position, proceed as follows: Press the handset “down” button. Keep pressing the button until the required desktop height is reached.

! NOTICE

The desktop will continue moving downwards until you release the button or the minimum height is reached.

3.1.3 Simple memory, end positions

ECS+ have editable memory for high and low (sit or stand) positions. This setting can also be used to avoid collision with furniture (e.g. a cabinet/pedestal).

How to set memory: Drive your table to the level you will store. Press both buttons 3 times (0.5-1 second between each pressing) Do the same procedure for your second store. The table will do a gentle rise to confirmation the setting.

To erase the setting, please follow manual reset as section 3.2

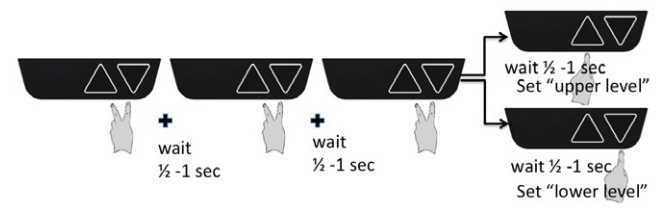

To drive the table outside the memory setting: Press the “up” or “down” button for 5 seconds to move beyond the preset.



3.2 Advanced functions, Manual reset

In case of exchanged parts (e.g. motor, electronics) there could be a need of a manual reset so columns and handsets correspond to each other. Even poor connection of the cables could create a need for resetting.

Manual reset



>7 sec



1-Press both buttons



2-Drive the columns
down to lowest level
3-Ready for use

Reset together with installation



1-Drive the columns
down to lowest level
2-Ready for use

 **CAUTION—Risk of pinching**

4 Maintenance & Repairs

4.1 Cleaning, Inspection and Storage

Clean the table frame by wiping it down with a microfiber cloth. Never use solvent or abrasive or corrosive compounds.

Products must be cleaned at regular intervals to remove dust and dirt and inspected for mechanical damage and normal wear and tear. Worn-out parts must be replaced.

Unplug the power cord if you do not intend to use the desk for a prolonged period of time.

4.2 User Maintenance

Products are closed units and require no internal maintenance.

Columns must be inspected at attachment points, wires, piston rod, cabinet, and plugs, check that columns function correctly.

- Inspect columns for loose connections and damaged plugs/wires.
- Inspect power supply for loose connections and damaged plugs/wires.
- The power supply and the handset is sealed and maintenance free.

4.3 Repairs

Check all screws and bolts after the first week of use and tighten screws and bolts where necessary to ensure safe operation of the table.

If the table cannot be raised or lowered, check the cable connection between:

- the power supply and the outlet.
- the power supply and the control unit / ECS+.
- the handset and the control unit / ECS+.
- the columns/motors and the control unit /ECS+.

If the table still is not operational, the control system may have triggered the overheating or duty cycle protection. Unplug the power cable and wait for at least 9 minutes and try again before proceeding.

If a control unit is replaced, a manual reset is required. Follow these steps as **section 3.2**.

If the table is still not operational, please contact your vendor for further assistance.

The control system is equipped with safety features; the intermittency function and the overheating protection and memory function

Overheat protection – The table will become inoperable if the overheating protection is triggered and will return to operation automatically once the heat has dissipated sufficiently.

If heavily loaded and driven continuously for a long period of time the motor might get very hot. The software observes this and if overheated system will shut down and you will have to wait about 9 minutes before being able to run again.

Memory function – The control system / ECS+ (each column) will retain information regarding the elevation of the table at all times. This information will remain stored even in case of power failure or if the power cable is disconnected from the power outlet.

Overload protection

If the total load on the equipment is too high you will only be able to drive for a short moment. The system will then stop and you need to release the table from load. Press button again.

Anti collision (optional)

The ECS+ can be equipped with an intelligent software pinch protection. During low rotation the currents to each connected motor is continuously measured and any variation of current is evaluated about 50 times each second.

If a collision is detected the system will stop and back off about 1 inch (25 mm)

IMPORTANT! Make sure to remove the blocking item causing the pinch before trying to operate the table again. Failure to do so may cause injury to user or equipment.

- **Soft start**

Progressive acceleration allows for soft starts and stops.

- **Speed**

the speed of the table varies with load.

4.4 Servicing of double-insulated products

In a double-insulated product, two systems of insulation are provided instead of grounding. No grounding means is provided on a double-insulated product, nor is a means for grounding to be added to the product.

Servicing a double-insulated product requires extreme care and knowledge of the system, and is to be done only by qualified service personnel.

Replacement parts for a double-insulated product must be identical to the parts they replace. A double insulated product is marked with the words "DOUBLE INSULATION" or "DOUBLE INSULATED". The symbol (square within a square) is also able to be marked on the product.

5 Appendix

5.1 Accessories, Series EE, ECS+

Control unit:



ECS+ White cover, black base **P/N see the chart below.**
 Width x depth x height 4,02" x 3,68" x 1,01", 2,50 oz. (100x91x27mm)

Stroke Inch	Stroke mm	AC-On	AC-Off
16.98	420	68003666	68003660
18.8	450	68003667	68003661
19	470	68003668	68003662
20.21	420	68003669	68003663
16.27	420	68003670	68003664
26.88	420	68003671	68003665

AC = Anti-Collision

Handset:



ECS+, black **P/N 68005680**
 Width x depth x height 2,76" x 1,99" x 0,88", 2,46 oz. (70x50,5x22 mm)
 Cable length 47" (1200 mm)

Power supply:



For 40mm/sec speed **P/N 68003761**
 Length x width x height 6,00" x 2,32" x 1,34", 12.63 oz.

Power supply:



For 32mm/sec speed **P/N 68002264**
 Length x width x height 4,52" x 2,16" x 1,49", 11.64 oz.

Cables:



Length 118" (3000mm) (primary side) **P/N 68002262**
 separately item, 4,86 oz.

Cable length secondary side at power supply
 68002264 L= 20"(2000mm) (68002235 L= 80-½" (500mm))

5.2 Dimensions column system: Series EE, ECS+ with 665 stroke Bifma

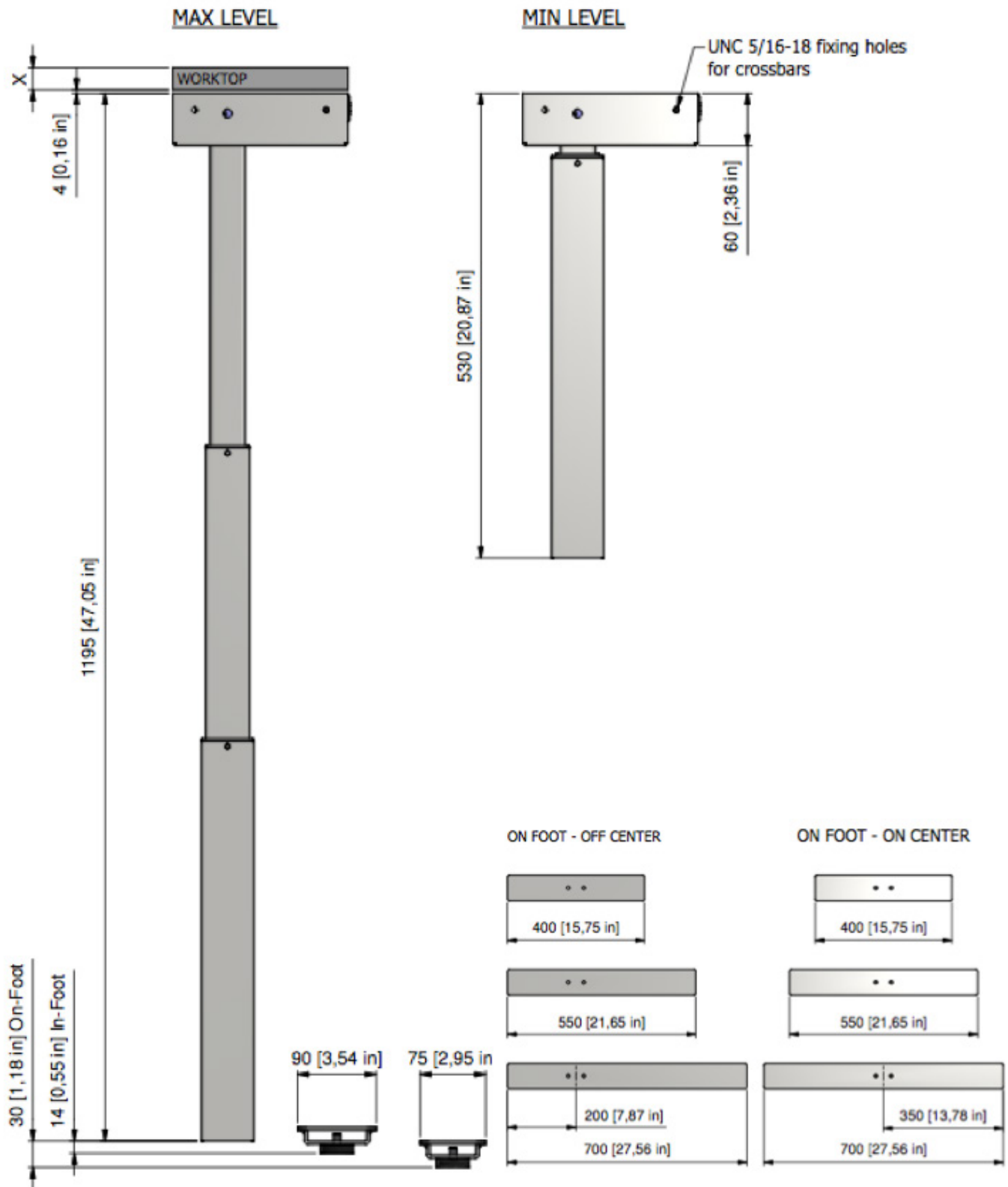

5.3 Dimensions column system: Series EE, ECS+ with 420 stroke

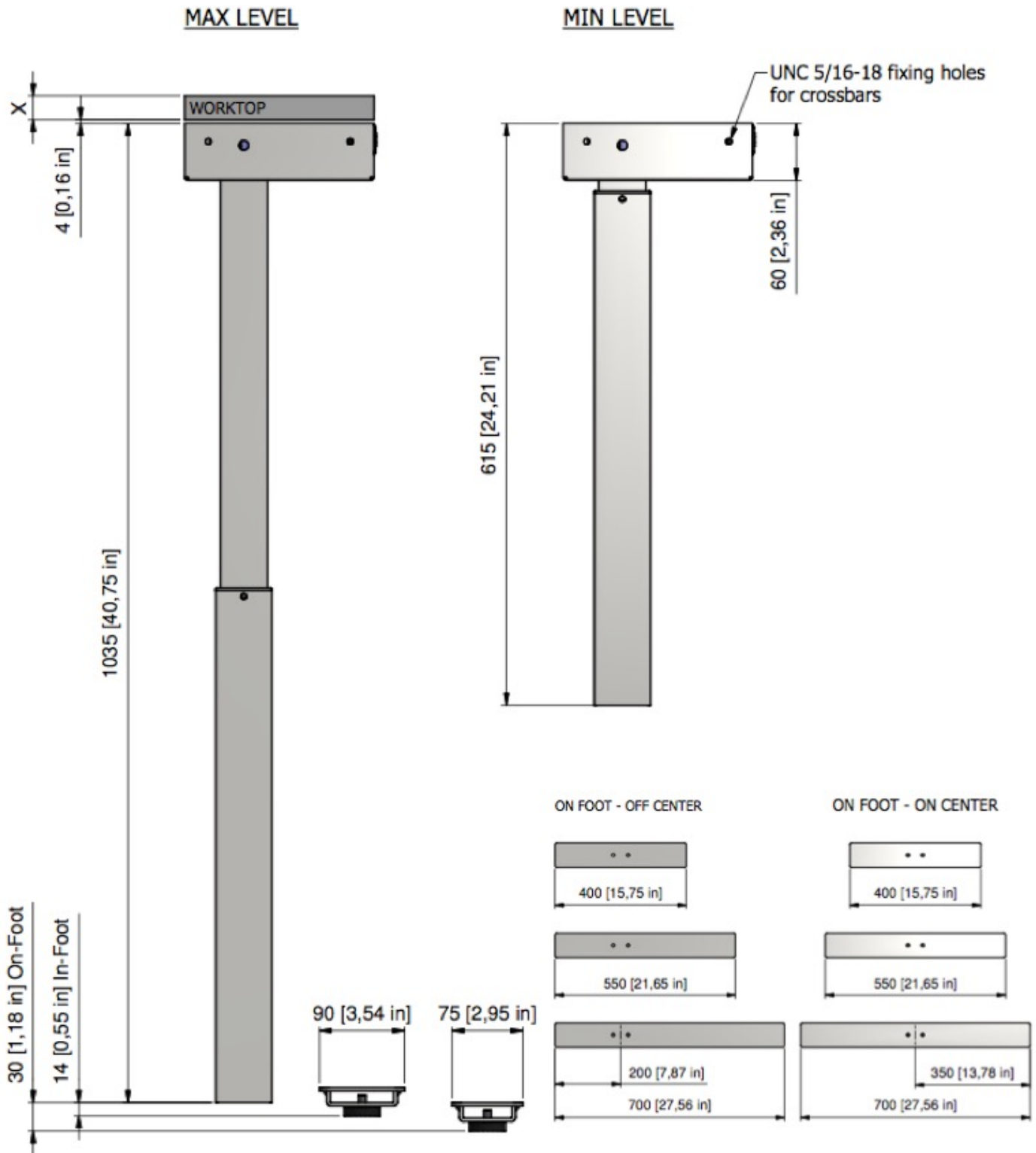

6.1 Performing a Reset

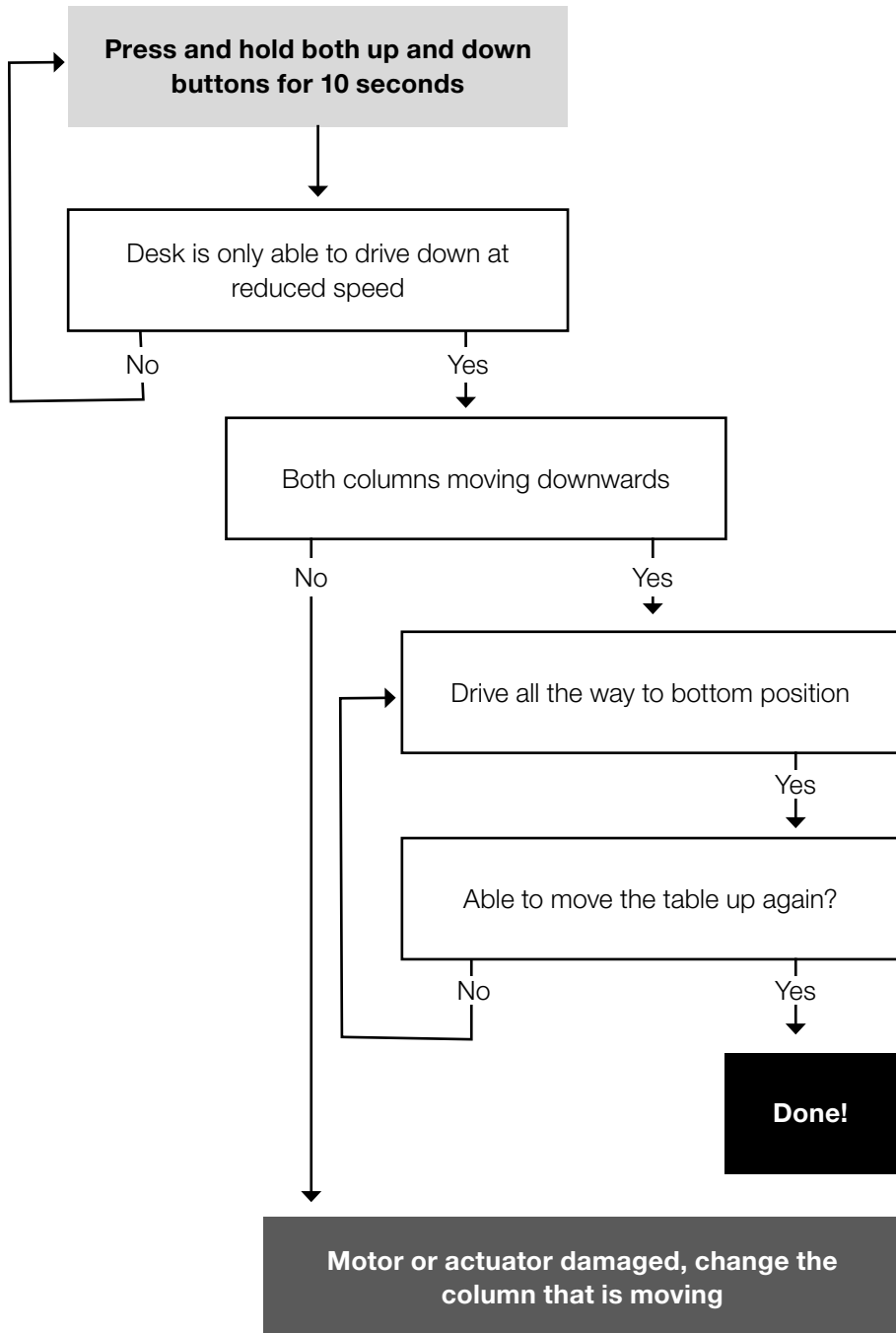

6.2 Troubleshooting

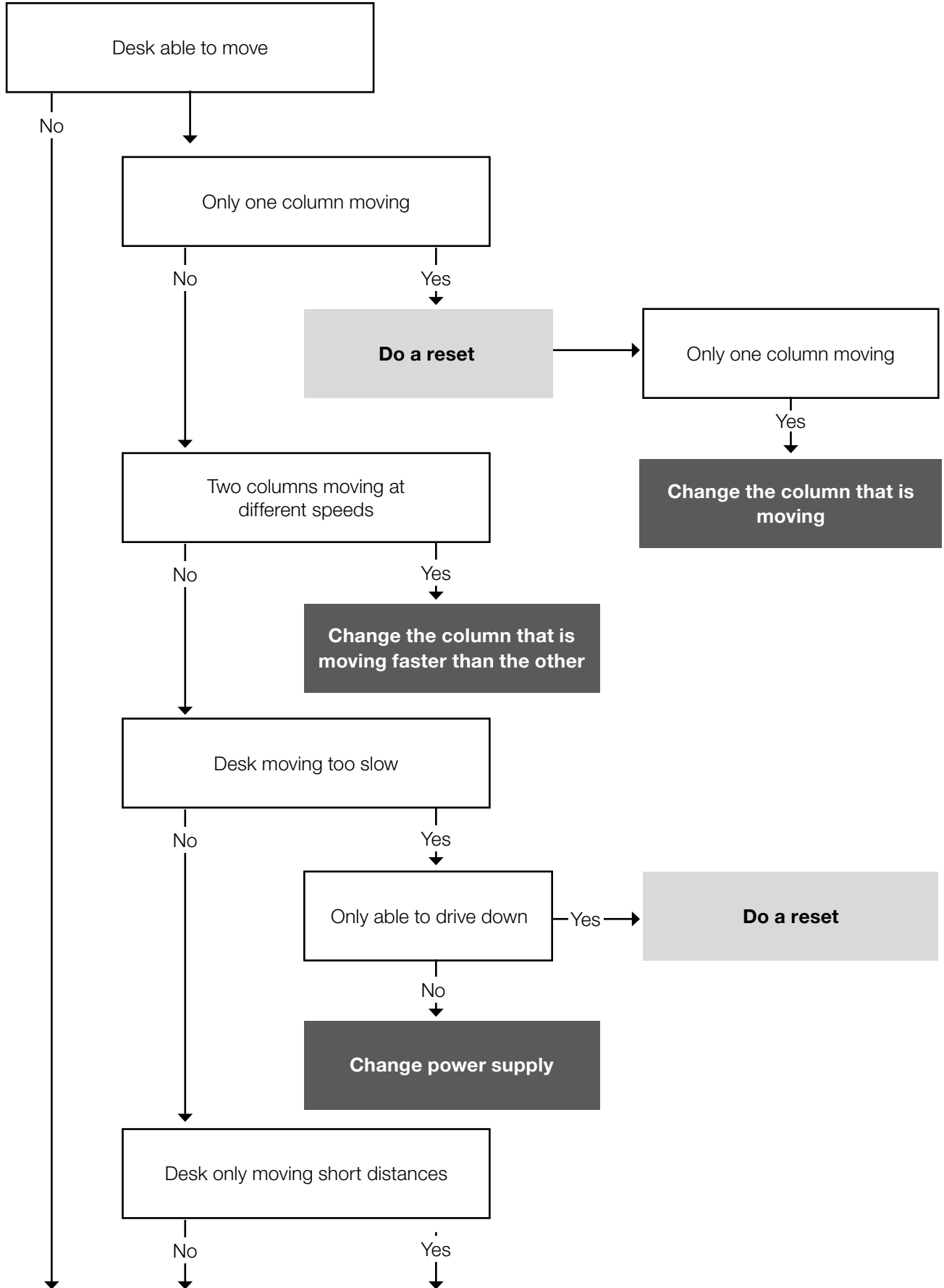

6.2 Troubleshooting

